

# W2-218 TWO-WAY 8-INCH FULL-RANGE WEATHER-RESISTANT LOUDSPEAKER



## FEATURES

- All-weather, multilayer fiberglass composite enclosure with stainless steel hardware
- Integral mounting points, included mounting yoke
- High power passive crossover and ferrofluid-cooled drivers
- Available in black or white finishes
- Powder-coated weather-resistant marine-grade aluminum grille and stainless steel yoke
- Available with built-in 100W autoformer for 70V/100V applications

## TECHNICAL SPECIFICATIONS

Operating Mode	Passive, low impedance model (W2-218) or 70V/100V model (W2-218T)	
Operating Environment	All conditions, suitable for continuous outdoor direct exposure	
Operating Range	70 Hz to 18 kHz	
Frequency Response	90 Hz - 15 kHz ( $\pm 3$ dB)	
Nominal Beamwidth	80° H x 60° V	
Transducers	LF 1 x 8" (203 mm) carbon fiber HF 1 x 1" (25.4 mm) exit, non-metallic diaphragm	
Max Input Ratings (8 ohm)	125W continuous, 250W program	
Sensitivity (1W/1m)	93 dB SPL (125 Hz to 13 kHz 1/3 octave bands) 92 dB SPL (250 Hz to 4 kHz speech range)	
Maximum Output	114 dB SPL / 120 dB SPL (peak)	
Nominal Impedance	8 ohms	
Minimum Impedance	3.5 ohms @ 15.3 kHz	
Crossover Frequency	2000 Hz	
W2-218T Autoformer Taps	<b>70V Taps:</b> 100W, 50W, 25W, 12.5W	<b>100V Taps:</b> 100W, 50W, 25W
Required Accessories	Electronic high pass filter (70 Hz, 24dB/octave)	

## APPLICATIONS

### MAIN PA or DISTRIBUTED

Theme and amusement parks · Water parks ·  
Outdoor entertainment centers · Cruise ships ·  
Music pavilions and musical fountains

### FILL or DELAY

Stadiums · Themed entertainment ·  
Cruise ships

## DESCRIPTION

Biamp's Community W2-218 is a compact two-way, full-range loudspeaker system featuring an 8-inch carbon fiber LF driver and a 1-inch HF compression driver with a weather-resistant, non-metallic, non-resonant polyimide diaphragm. Drivers are ferrofluid-cooled to improve heat transfer, resulting in higher power handling and reduced distortion.

Like all W SERIES loudspeakers, the W2-218 is designed to provide high quality music and voice reproduction in applications requiring extreme weather-resistance. The W2-218's compact enclosure features unmatched durability and ruggedness and is engineered for use in permanent installations. The loudspeaker enclosure and faceplate are constructed of hand-laminated multilayer fiberglass composite, resulting in extreme structural strength. A three-layer Weather-Stop™ grille provides weather-resistance to the internal components, while all exposed hardware is stainless steel or powder-coated aluminum. A weather-resistant powder-coated stainless steel mounting yoke is included.

The W2-218 is also available in an optional "autoformer" version (model W2-218T), with a built-in 100-watt autoformer for 70V/100V lines with selectable taps at 100, 50, 25 and 12.5 watts. Ease of installation makes this product an industry standard.

## PHYSICAL

Input Connection	<b>W2-218:</b> 16-2 SJOW (12 ft / 4m)	<b>W2-218T:</b> 18-5 SJOW
Mounting Provisions	Two (2) 1/2-13 threaded mounting points; yoke included	
Environmental	IP 55W rated per IEC 60529	
Dimensions H x W x D	9.25" x 15.5" x 10.14" (235 x 394 x 258 mm)	
Weight (with yoke)	<b>W2-218:</b> 18.6 lbs (8.4 kg)	<b>W2-218T:</b> 21.4 lbs (9.7 kg)
Unit Weight	23.2 lbs (10.5 kg)	26 lbs (11.8 kg)
Shipping Weight		
Enclosure	Hand-laminated fiberglass	
Grille	Powder-coated, zinc-plated marine grade aluminum (5052 alloy), black or white finish (three-layer Weather-Stop™)	
Finish	Black or white gelcoat	
Accessories (included)	Mounting yoke	

## OPTIONS

Accessories (optional)	<b>PMB-1RR</b> pole mount bracket for a single loudspeaker <b>PMB-2RR</b> pole mount bracket for mounting 2 loudspeakers
------------------------	---

Recommended signal processing is available at [www.biamp.com/community](http://www.biamp.com/community).

Biamp strives to improve its products on a continual basis. Specifications are therefore subject to change without notice.

Data presented on this spec sheet represents the basic performance specifications for the model. For a detailed analysis of this loudspeaker's performance, please download the GLL file and/or the CLF file from [www.biamp.com](http://www.biamp.com).

# W2-218 TWO-WAY 8-INCH FULL-RANGE WEATHER-RESISTANT LOUDSPEAKER

## FREQUENCY RESPONSE (dB SPL)

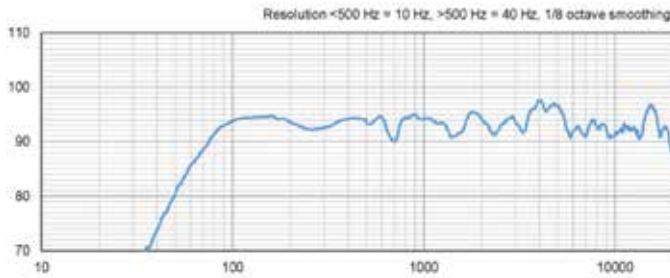

## BEAMWIDTH (Degrees)

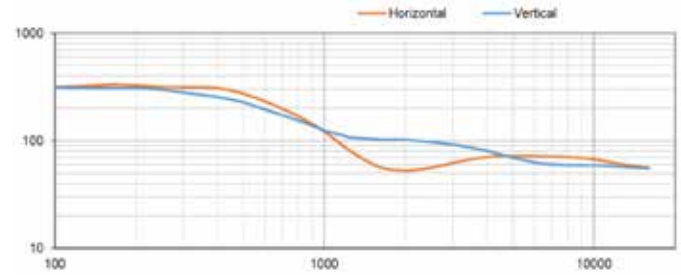

## IMPEDANCE (Ohms)

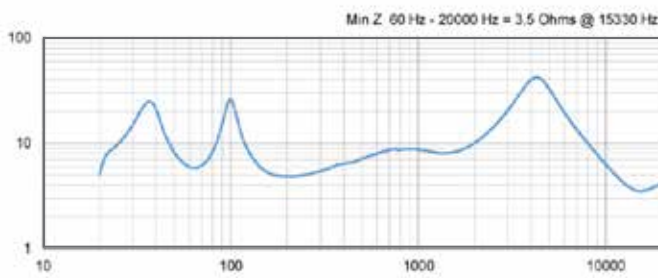

## AXIAL Q

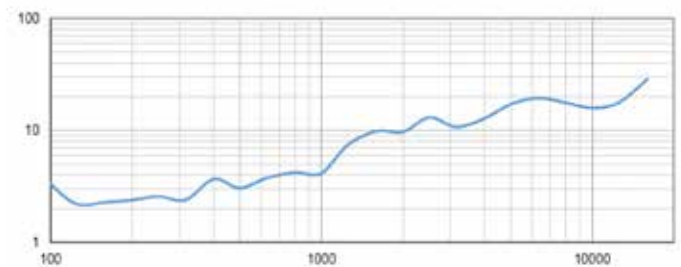

## IMPEDANCE 100W AUTOFORMER (Ohms)

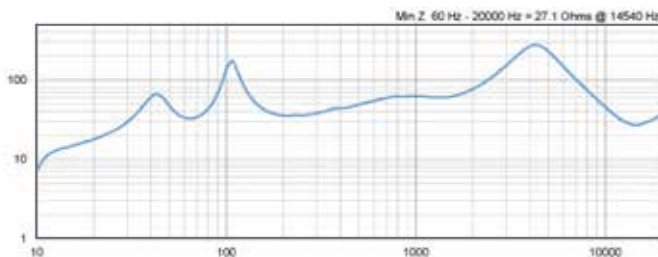

## ARCHITECTS & ENGINEERS SPECIFICATIONS

The loudspeaker system shall be a two-way, full-range, weather-resistant bass reflex design with one 8-inch carbon fiber low frequency woofer and one 1-inch exit high frequency driver with a non-metallic polyimide diaphragm mounted on a fiberglass high frequency horn. Drivers shall be connected to an integral crossover with a crossover frequency of 2 kHz. The input connection shall be one 12-foot (4 m) SJOW #16 gauge cable with stripped ends. The loudspeaker enclosure shall be of multilayer fiberglass composite with a powder-coated perforated zinc-plated marine grade aluminum grille backed by weather-resistant material. There shall be two 1/2-13 rigging points. The system shall have an amplitude response of 90 Hz -15 kHz ( $\pm 3$  dB), input capability of 32V RMS, 93 dB sensitivity at one meter nominal impedance. The nominal dispersion shall be  $80^\circ$  H x  $60^\circ$  V from 1.6 kHz - 12.5 kHz. The loudspeaker shall measure 9.25 in. (235 mm) high x 15.5 in. (394 mm) wide x 10.14 in. (258 mm) deep. Warranty shall be 5 years for the loudspeaker system and 15 years for the structural integrity of the enclosure. The loudspeaker shall be Community W2-218.

# W2-218 TWO-WAY 8-INCH FULL-RANGE WEATHER-RESISTANT LOUDSPEAKER

## TECHNICAL DRAWING / DIMENSIONS / FINISH

**H x W x D**  
 9.25 x 15.5 x 10.14 inches  
 (235 x 394 x 258 mm)

**Unit Weight**  
 W2-218: 18.6 lbs (8.4 kg) (includes yoke)  
 W2-218T: 21.4 lbs (9.7 kg) (includes yoke)

**Shipping Weight**  
 W2-218: 23.2 lbs (10.5 kg) (includes yoke)  
 W2-218T: 26 lbs (11.8 kg) (includes yoke)

**Grille:**  
 Three-layer Weather-Stop™ powder-coated, zinc-plated marine grade aluminum (5052 alloy)

**Enclosure / Finish**  
 Hand-laminated fiberglass with gelcoat finish; White (RAL 9003) or Black (RAL 9005)

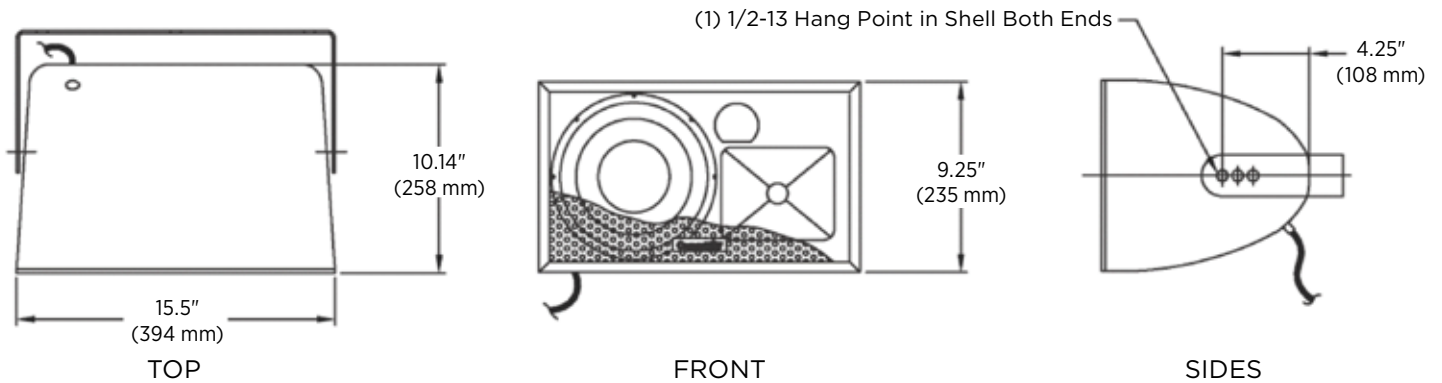

### YOKE DETAIL

